

Performance Curves

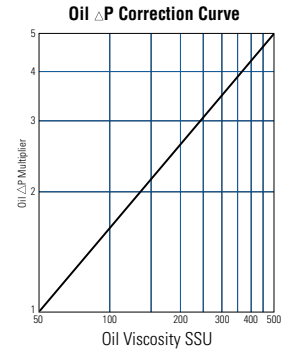
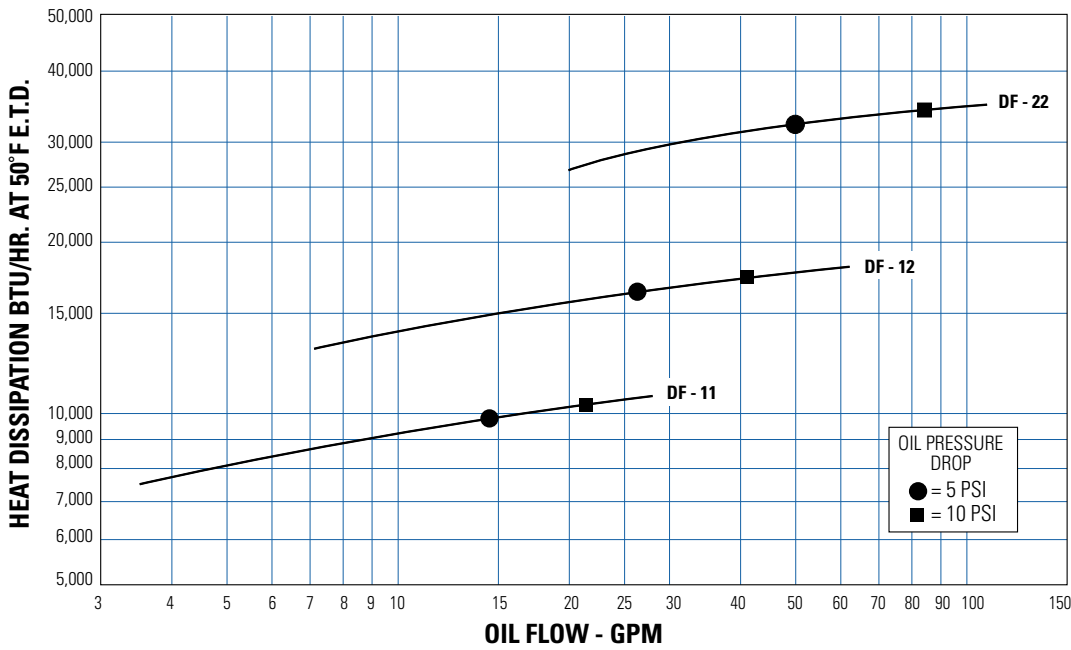

Performance Curves are based on 50 SSU oil entering the cooler 50°F higher than the ambient air temperature used for cooling. This is referred to as a 50°F E.T.D.

Step 1 Determine the Heat Load. Heat load may be expressed as either horsepower or BTU/Hr. To convert horsepower to BTU/Hr.:
 $BTU/HR = \text{Horsepower} \times 2545$

Step 2 Determine Entering Temperature Difference. The entering oil temperature is generally the maximum desired oil temperature.
 Entering oil temperature – Ambient air temperature = E.T.D.

Step 3 Determine the Corrected Heat Dissipation to use the curves.
 $\text{Corrected Heat Dissipation} = \text{BTU/HR heat load} \times \frac{50^\circ\text{F} \times C_v}{\text{E.T.D.}}$

Step 4 Enter curves at oil flow through cooler and curve heat dissipation. Any curve above the intersecting point will work.

Step 5 Determine Oil Pressure Drop from Curves:
 ● = 5 PSI; ■ = 10 PSI; Multiply pressure drop from curve by correction factor found in oil Δ P correction curve.

Oil Temperature

Typical operating temperature ranges are:

Hydraulic Motor Oil	120°F - 180°F
Hydrostatic Drive Oil	160°F - 180°F
Engine Lube Oil	180°F - 200°F
Automatic Transmission Fluid	200°F - 300°F

C_v Viscosity Correction

Average Oil Temp °F	OIL				
	SAE 5 110 SSU at 100°F 40 SSU at 210°F	SAE 10 150 SSU at 100°F 43 SSU at 210°F	SAE 20 275 SSU at 100°F 50 SSU at 210°F	SAE 30 500 SSU at 100°F 65 SSU at 210°F	SAE 40 750 SSU at 100°F 75 SSU at 210°F
100	1.14	1.22	1.35	1.58	1.77
150	1.01	1.05	1.11	1.21	1.31
200	.99	1.00	1.01	1.08	1.10
250	.95	.98	.99	1.00	1.00

Thermostatic Temperature Control Option (DC)

This controller was designed to mount on the cooler without requiring extensive wiring or plumbing. It provides accurate temperature control by cycling the cooling fan(s) to maintain desired oil temperature.

- 12 or 24 volt operation
- Adjustable temperature settings range from 100°F thru 210°F in 20°F increments
- For use with one or two fan models
- Temperature sensor provided
- Wiring provided for remote manual override
- Mounting hardware included

Part Number	Description
96171	Electronic Fan Control Kit
68790	Replacement Control Only
67699	Replacement Sensor Only

Side View

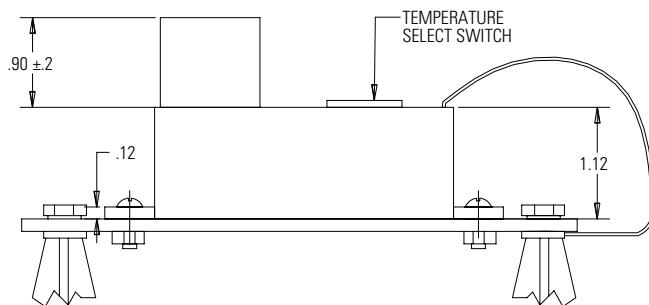

Connection Assembly

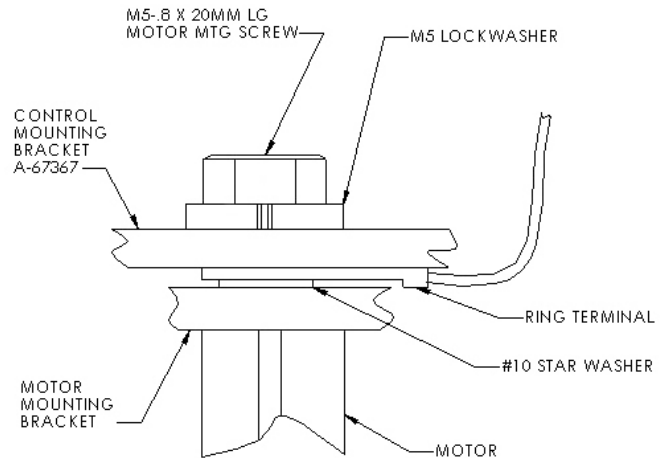

Top View

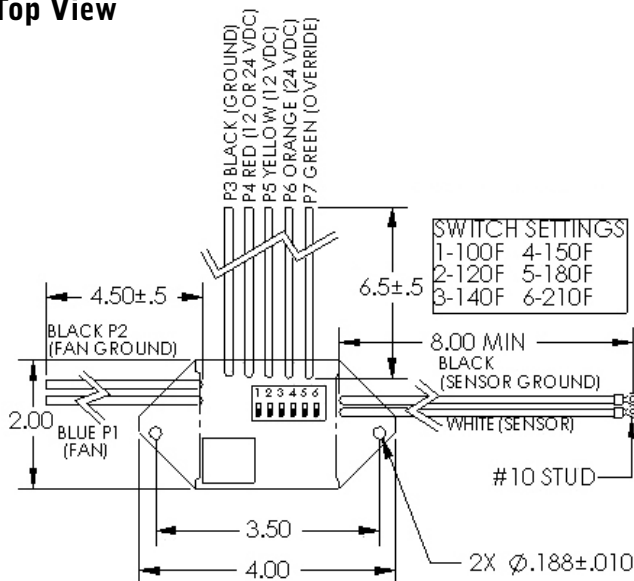

Electrical Schematic

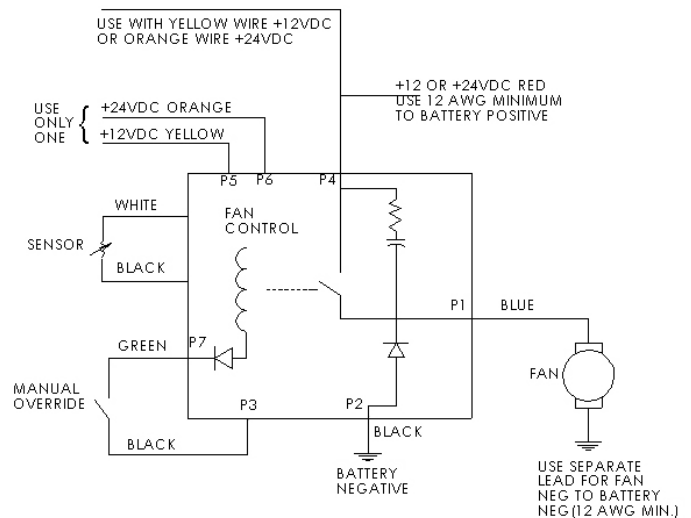

NOTE: This switch should be fused to prevent damage if ground is lost. A 30 amp fuse is required in the power supply.